

CUSTOMER THOMPSON FABRICATION

DESCRIPTION 1.890 DIA TUBE

PLEASE INDICATE
EXPOSED SURFACES

(VISIBLE TO THE EYE
AFTER PRODUCT ASSEMBLY)
IF THERE IS NO EXPOSED
SURFACES PLEASE INDICATE.

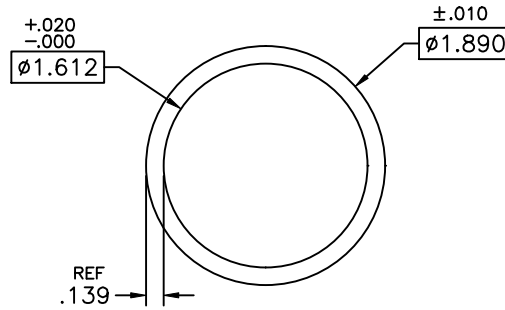

ALUMINUM ASSOCIATION STANDARD TOLERANCES
APPLY UNLESS SPECIFIED OTHERWISE

UNSPECIFIED: WALL THICKNESS $\frac{1}{16}$

UNSPECIFIED RADIUS $\frac{1}{16}$

		DIFF. RATING -	
EST.AREA .765	IN ²	DWN BY Angela	PRESS -
EST.WT. .918	LBS/FT.	CKD BY	CAV. -
EST.PER. 11.002	IN	SCALE 1=1	BACK #-
OUT PER. 5.938	IN	CODE -	BOL # -
EXPD PER. -	IN	DATE 03-15-17	RATIO -
FACTOR 12		POCKET AREA -	BLADE -
C.C.D. 1.890	IN	ALLOY 6005-T5	